

FEATURES

- Ultra high input resistance, typically $5 \times 10^{10} \Omega$
- Dry-contact capacitive coupling
- Input capacitance as low as 10^{-11} F
- Upper 3dB point typically 20kHz
- Operates with bipolar power supply from $\pm 2.4\text{V}$ to $\pm 5.5\text{V}$
- Sensors supplied in a custom package with exposed balls for surface mount assembly.

APPLICATIONS

- Contact ECG signal detection for:
 - Non-critical patient monitoring equipment
 - Emergency response diagnostics
 - Lifestyle sports and health products
 - Suitable for long-term and remote monitoring

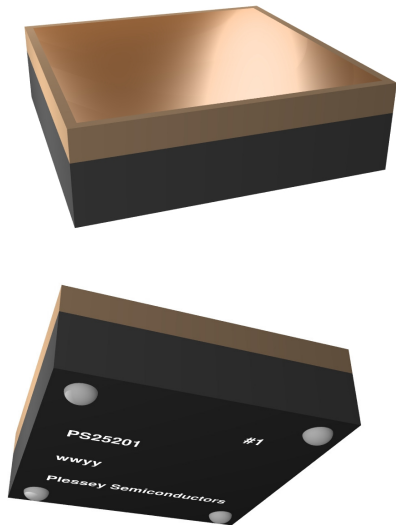

Fig. 1 Impression of PS25201 Sensor

Ordering Information
PS25201
Custom package (drawing to be released)
-25 °C to +75 °C

Plessey Semiconductors Electric Potential Integrated Circuit (EPIC) product line targets a range of applications.

The PS25201 is an ultra high impedance solid state ECG (electrocardiograph) sensor. It can be used as a dry contact ECG sensor without the need for potentially dangerous low impedance circuits across the heart. The resolution available is as good as or better than conventional wet electrodes.

The device uses active feedback techniques to both lower the effective input capacitance of the sensing element (C_{in}) and boost the input resistance (R_{in}). These techniques are used to realise a sensor with a frequency response suitable for both diagnostic and monitoring ECG applications.

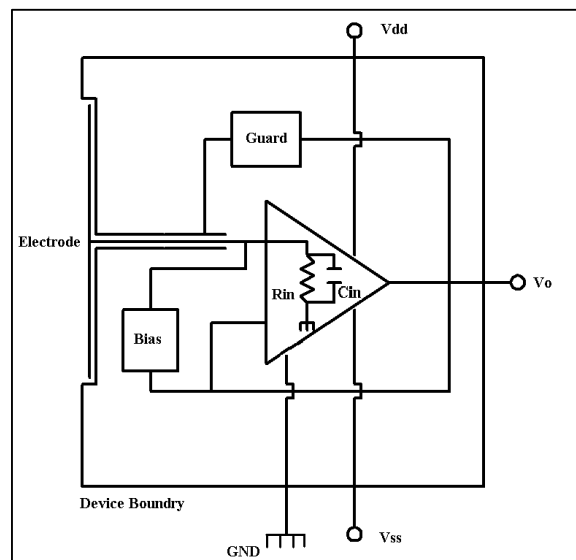

Fig. 2 Internal circuit of EPIC ECG Sensor

ELECTRICAL CHARACTERISTICS

$T_{amb} = -25^{\circ}\text{C}$ to $+75^{\circ}\text{C}$, $V_{dd}/V_{ss} \pm 2.4\text{V}$ to $\pm 5.5\text{V}$. The electrical characteristics are guaranteed by either production test or by design and characterisation. They apply within the specified ambient temperature and supply voltage unless otherwise stated.

Characteristics	Value			Units	Conditions
	Min.	Typ.	Max.		
Supply voltage	± 2.4		± 5.5	V	Bipolar, Gnd=0V
Supply current		3.0		mA	
Input resistance (Rin)		50		G Ω	
Input capacitance		10		pF	
Voltage Gain (Av)		10			
Effective input resistance (Rine)			50	G Ω	
Effective input capacitance (Cine)	100			fF	
Coupling capacitance		250		pF	Sensor to skin
Lower 3dB point		0.050		Hz	Defined as $1/(2 \cdot \pi \cdot R_{ine}(C_c + C_{ine}))$
Upper 3dB point		20		kHz	
Noise		tdb			
Supply voltage	± 2.4		± 5.5	V	Bipolar, Gnd=0V

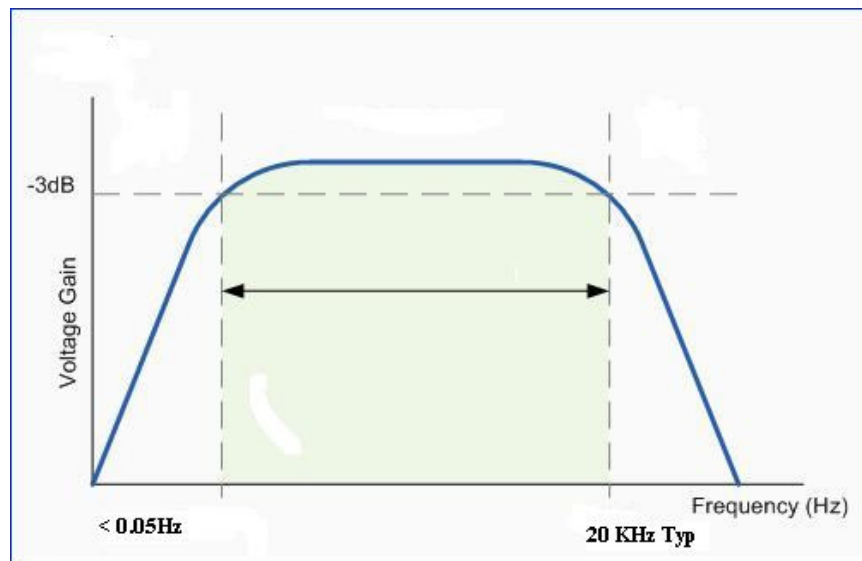

Fig. 3 Typical Bode Plot for EPIC ECG Sensor

PIN ASSIGNMENT

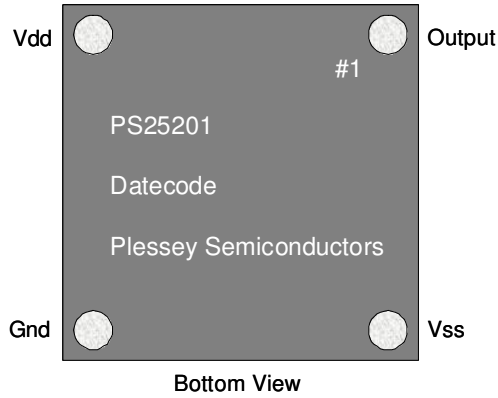

Fig. 4 Pin Assignment for the PS25201 – Bottom View

MECHANICAL DIMENSIONS

A preliminary package diagram is shown below. This is certain to change and so should only be used for illustration purposes.

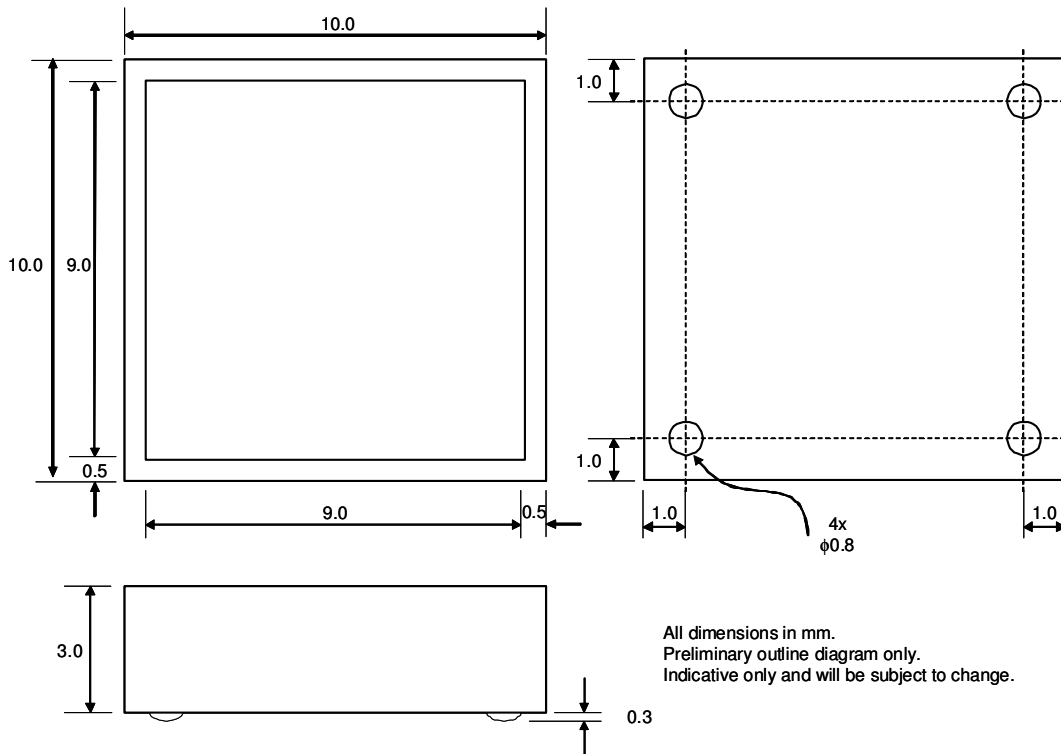

Fig. 5 Provisional Package Dimensions

APPLICATION OF THE ECG SENSOR

Because of the large coupling capacitance to the body (around 250pF) the EPIC sensor's internal electrometer can be used in differential mode to recover true surface potential ECG signals from the surface of the skin. A typical ECG signal at the surface of the skin is 1mV p-p.

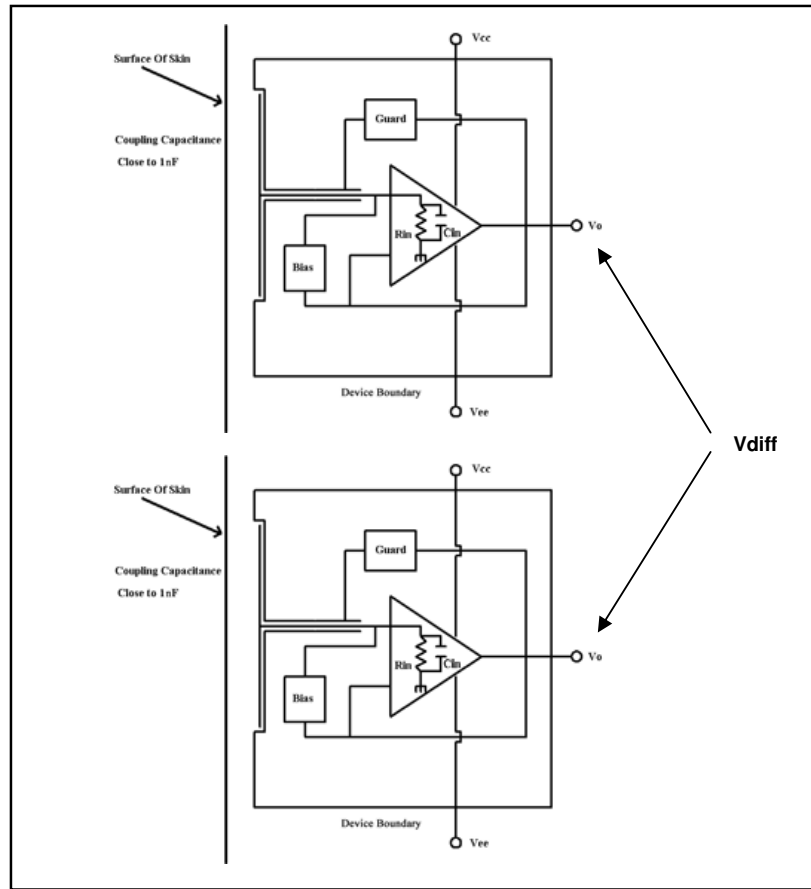

Fig. 6 Differential measurement of body (skin) surface potential to produce ECG trace



Fig. 7 Comparison of two vectors from a pair of EPIC sensors (top) and two conventional Ag/AgCl electrodes (bottom)

**For further information about this and other products, please visit:
www.plesseysemiconductors.com**

Legal Notice

Product information provided by Plessey Semiconductors Limited ("Plessey") in this document is believed to be correct and accurate. Plessey reserves the right to change/correct the specifications and other data or information relating to products without notice but Plessey accepts no liability for errors that may appear in this document, howsoever occurring, or liability arising from the use or application of any information or data provided herein. Neither the supply of such information, nor the purchase or use of products conveys any licence or permission under patent, copyright, trademark or other intellectual property right of Plessey or third parties.

Products sold by Plessey are subject to its standard Terms and Conditions of Sale that are available on request. No warranty is given that products do not infringe the intellectual property rights of third parties, and furthermore, the use of products in certain ways or in combination with Plessey, or non-Plessey furnished equipments/components may infringe intellectual property rights of Plessey.

The purpose of this document is to provide information only and it may not be used, applied or reproduced (in whole or in part) for any purpose nor be taken as a representation relating to the products in question. No warranty or guarantee express or implied is made concerning the capability, performance or suitability of any product, and information concerning possible applications or methods of use is provided for guidance only and not as a recommendation. The user is solely responsible for determining the performance and suitability of the product in any application and checking that any specification or data it seeks to rely on has not been superseded.

Products are intended for normal commercial applications. For applications requiring unusual environmental requirements, extended temperature range, or high reliability capability (e.g. military, or medical applications), special processing/testing/conditions of sale may be available on application to Plessey.

Data Sheet 291339 Issue 1

Plessey Semiconductors Ltd.

Design & Technology Centre, Delta 500, Delta Business Park, Great Western Way, Swindon, UK SN5 7XE

Tel: +44 1793 518000

Fax: +44 1793 518030

Web: www.plesseysemi.com